



Chen Hsong Europe



JETMASTER LARGE MK6 SERIES

800 - 1650 TON TOGGLE- *Injection moulding machine*



JETMASTER LARGE MK6 SERIES 800-1650 TON
Injection moulding machine

EUROMAP STANDARD

Hole pattern and ejector pattern according to Euromap standards*.
T-slot or other pattern possible on request.



EUROPEAN COMPONENTS

Standard European components:

Hydraulic valves: Bosch Rexroth

Hydraulic pump: Eckerle

Linear transducers: Gefran or Novotechnik

Electrical components: Siemens, Schneider, Telemecanique, PILZ

*Hole pattern/ejector pattern may differ from standard due to platen design.

▶ PPC2200 CONTROLLER APPLICATION

The PPC2200 controller from B&R offers an integrated solution for the automation of the Chen Hsong injection moulding machines. High-speed applications and complete production cells can be implemented with B&R. The integrated Extremely Fast Control technology enables the sampling of rapidly changing input signals, allowing the injection process to be controlled with high precision. The 15.6" screen area with touch function enables a clear process visualization.



INOVANCE SERVO DRIVE SYSTEM ◀

The Inovance servo drive system is designed dedicated for injection moulding machines. This system provides high performance, precision, low noise and easy maintenance. For machines using this servo drive, energy saving up to 80% can be achieved.



ENERGY SAVING

The MK6 system, with speed controlled servomotor, drives a fixed internal gear pump. The system pressure is measured real-time by a pressure sensor. In this way it can provide the required flow according the requirement to eliminate non-functioning consumption. In total this leads to lower energy consumption, high precision, low noise and low inertia.

STANDARD AND OPTIONAL FEATURES

CLAMPING UNIT	STANDARD	OPTION
Automatic mould height adjust	•	
Hydraulic safety device	•	
Core puller on moving platen	2	
Additional core pullers (up to 6 core pullers)		•
Airblow on fixed and moving platen	1 + 1	
Parallel core movement		•
Parallel ejector movement		•
Euomap 2 platen design *	•	
Euomap 13 for core and ejector	•	
Euomap 18 for robot mounting	•	
Euomap 67 for robot communication	•	
Euomap 70 and 70.1		•
Larger maximum mould height		•
Automatic lubrication on toggle	•	
Automatic lubrication on mould height adjust	•	
Anti-skid plates on horizontal surfaces	•	
Automatic front door	•	
OTHERS		
Up to 16 zones integrated hotrunner System (Euomap 14 standard)		•
Power sockets 3-phase 400V 32A and 16A	One each	
Power sockets 2-phase 240V 16A	2	
Waterflow regulators (more available upon request)	6 circuits	

*Hole pattern/ejector pattern may differ from standard due to platen design.



INJECTION UNIT

STANDARD

OPTION

Ceramic heater bands	•	
Nitrated screw and barrel	•	
Bi-metallic screw and barrel		•
PET or PVC screw features		•
Adjustable backpressure	•	
Barrel shut-off nozzle		•
Hydraulic/pneumatic sequential injection (up to 12 valves)		•
Linear transducer on injection stroke	•	
Linear transducer on injection unit stroke	•	
Screw speed indicator	•	
Controlled barrel cooling	•	
Barrel insulation		•
Central lubrication points	•	
Anti-skid plates on horizontal surfaces	•	
Parallel plasticizing		•

CONTROLLER

B&R controller	•	
15.6" HD TFT display with touch function	•	
LED backlight	•	
Free programmable cores	•	
Free I/O Configuration	•	
Sequence editor	•	
High-precision mould safety	•	
PowerLink -based Extremely Fast Control technology	•	
Ethernet interface for teleservice via internet	•	
USB interface	•	
Euromap 67 interface	•	
Industry 4.0		•
OPC-UA		•

Injection unit	Unit	JM800-MK6			JM1000-MK6		
Screw Diameter	mm	90	98	100	98	110	120
Screw L/D Ratio	L/D	24	22	19.6	24.7	22	20.2
Screw Stroke	mm		500			550	
Swept Volume	cm ³	3179	3770	4749	4146	5224	6217
Injection Weight (PS)	g	2893	3430	4322	3773	4754	5658
Injection Pressure (Max)	kgf/cm ²	2170	1840	1460	2320	1840	1550
Injection Rate	cm ³ /s	607	720	907	700	885	1053
Screw Rotation Speed (Max)	rpm		130			110	
Nozzle Contact Force (Max)	t		16.7			16.7	
Nozzle Stroke	mm		560			595	
Clamping unit							
Clamping Force (Max)	t		800			1000	
Opening Stroke	mm		1050			1230	
Mould Platen (HxW)	mm		1440x1440			1630x1630	
Space Between Tie Bars (HxV)	mm		1020x1020			1160x1160	
Max.Mould Thickness	mm		1000			1160	
Min.Mould Thickness	mm		400			450	
Max. Daylight	mm		2050			2390	
Ejector Force	t		18.2			21.5	
Ejector Stroke	mm		280			320	
Centre Ring Diameter	mm		250			250	
Others							
System Pressure	MPa		17.5			17.5	
Pump Motor	kW		108			122	
Electrical Heating	kW		46.9			58.7	
Temperature Control Zones	Zones		6+Nozzle			6+Nozzle	
Machine Dimensions (LxWxH)	m		10.9x2.41x2.5			11.9x2.7x3.3	
Oil Tank Capacity	L		1050			1250	
Machine Weight	t		34			44	

JM1200-MK6			JM1400-MK6			JM1650-MK6		
110	120	130	120	130	140	130	140	150
24	22	20.3	23.8	22	20.4	23.7	22	20.5
600			650			700		
5699	6782	7960	7347	8623	10001	9286	10770	12364
5186	6172	7244	6686	7847	9101	8450	9801	11251
2190	1840	1570	2110	1800	1550	2090	1800	1570
875	1045	1226	1035	1215	1409	1195	1390	1596
110			100			95		
16.7			16.7			16.7		
700			720			800		
1200			1400			1650		
1310			1500			1600		
1770x1770			2030x1930			2190x2070		
1250x1250			1450x1350			1550x1430		
1250			1400			1500		
500			650			700		
2560			2900			3100		
21.5			35.2			35.2		
320			400			400		
250			250			250		
17.5			17.5			17.5		
153			182			206		
70.1			77.6			95.4		
6+Nozzle			6+Nozzle			6+Nozzle		
12.6x2.8x3.4			13.8x3.2x3.6			14.8x3.2x3.7		
1600			1800			2000		
55			74			97		

JM800-MK6

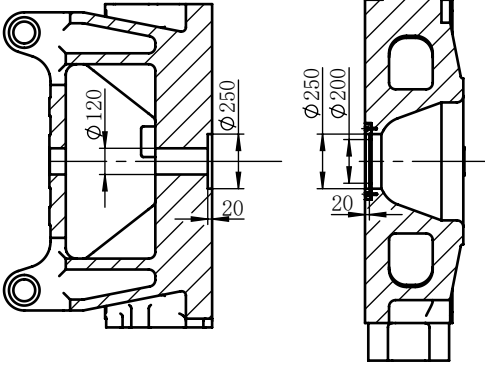
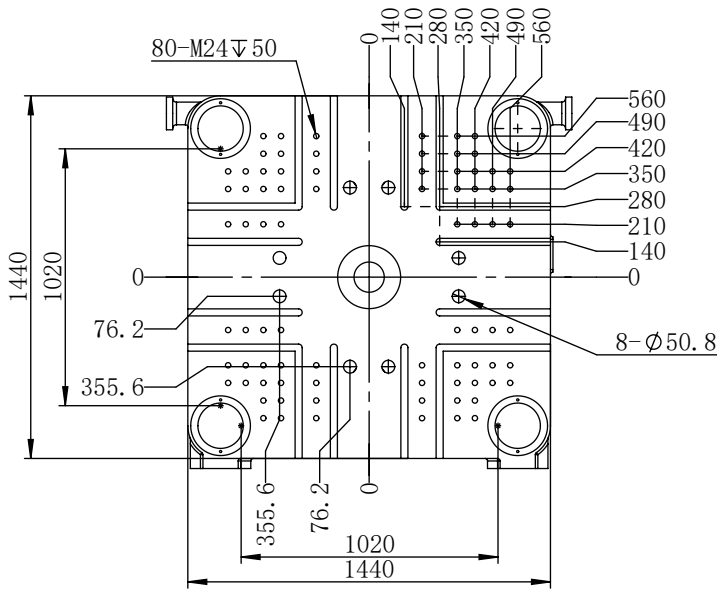

JM1000-MK6

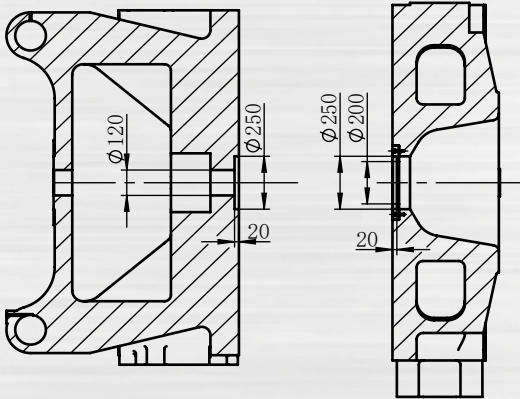
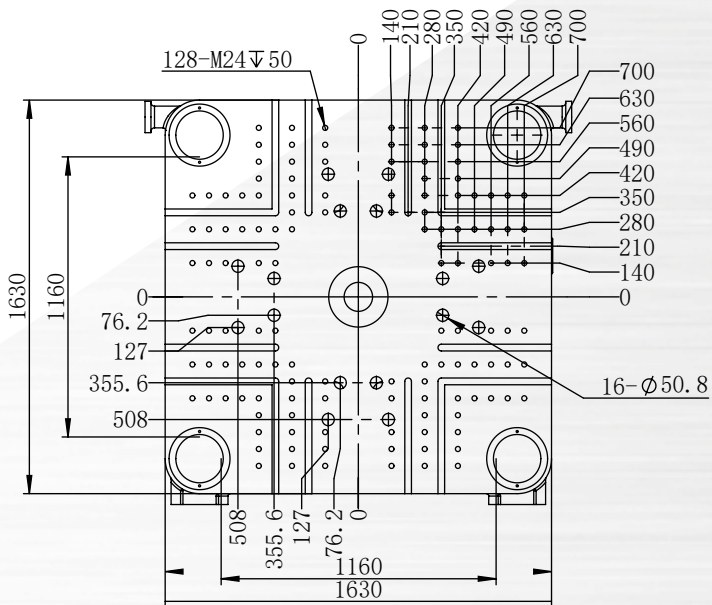

JM1200-MK6

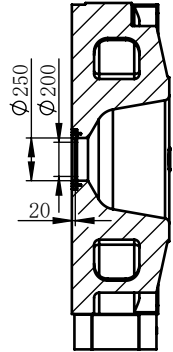
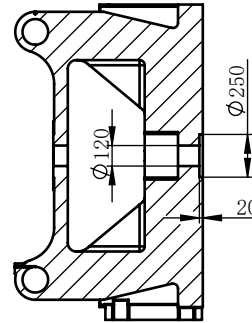
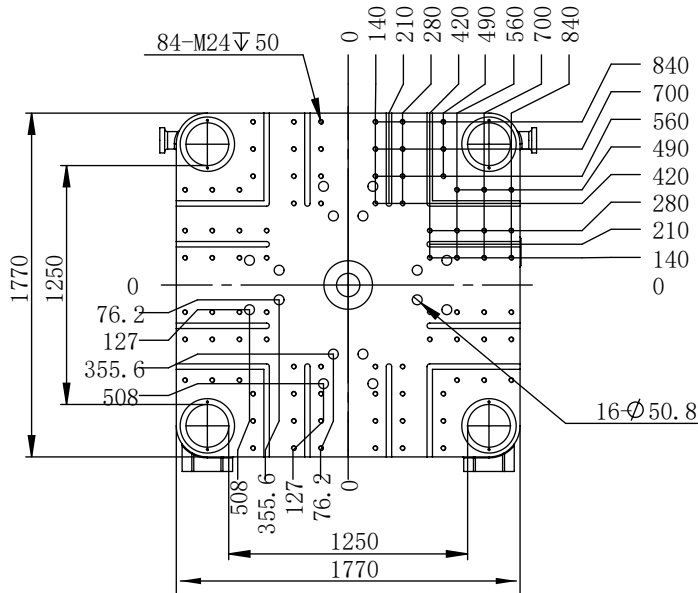

JM1400-MK6

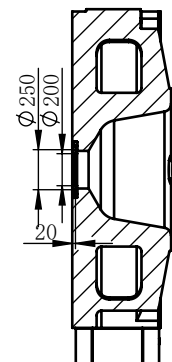
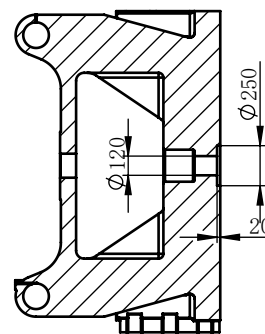
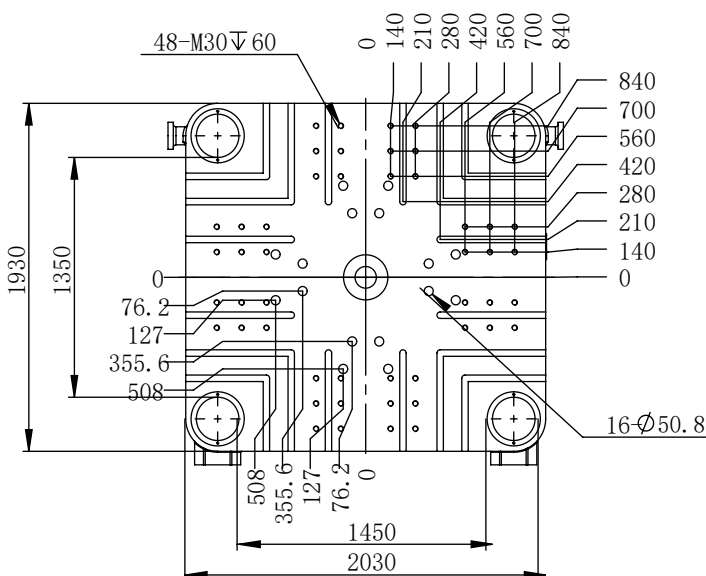

JM1650-MK6

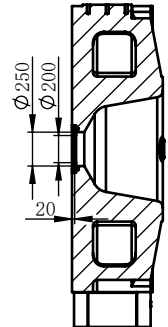
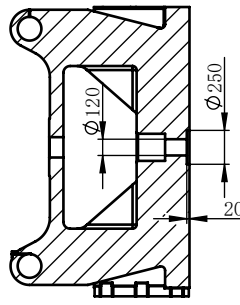
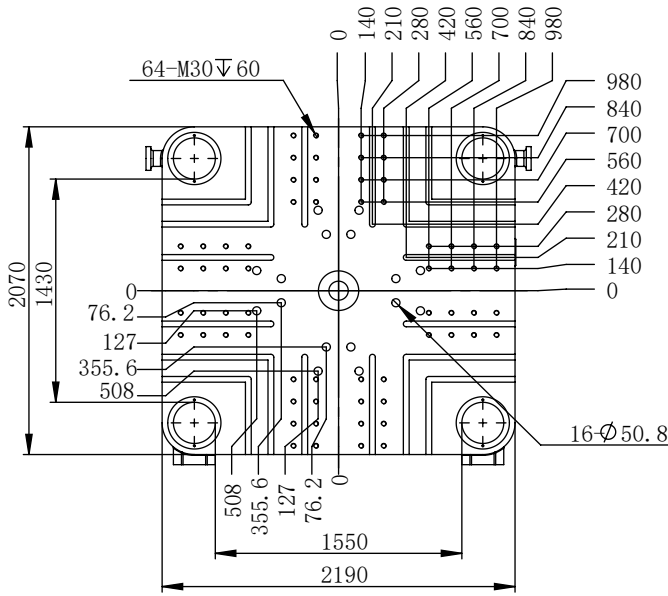

T-slot Section

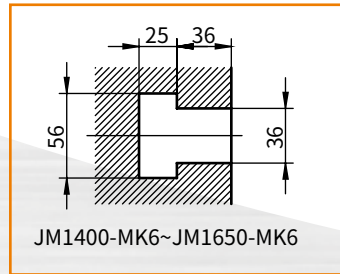
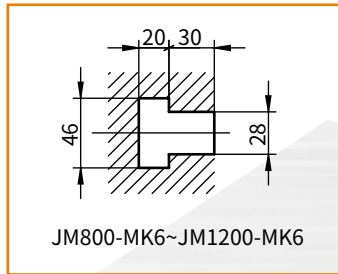

JETMASTER LARGE MK6 SERIES - Platen Mount Hole (According to Euromap 18)

Model	Distance between tie bars	Euromap 2	Mount hole size and position (see figure right)					
			A1	A2	A3	B1	B2	C1
JM800-MK6	1020x1020	S 1000x1000	70	175	280	420	630	M24
JM1000-MK6	1160x1160	S 1120x1120	70	175	280	420	700	M24
JM1200-MK6	1250x1250	S 1250x1250	70	175	280	560	840	M24
JM1400-MK6	1450x1350	S 1400x1250	70	175	280	560	840	M24
JM1650-MK6	1550x1430	S 1400x1400	70	210	350	560	840	M24

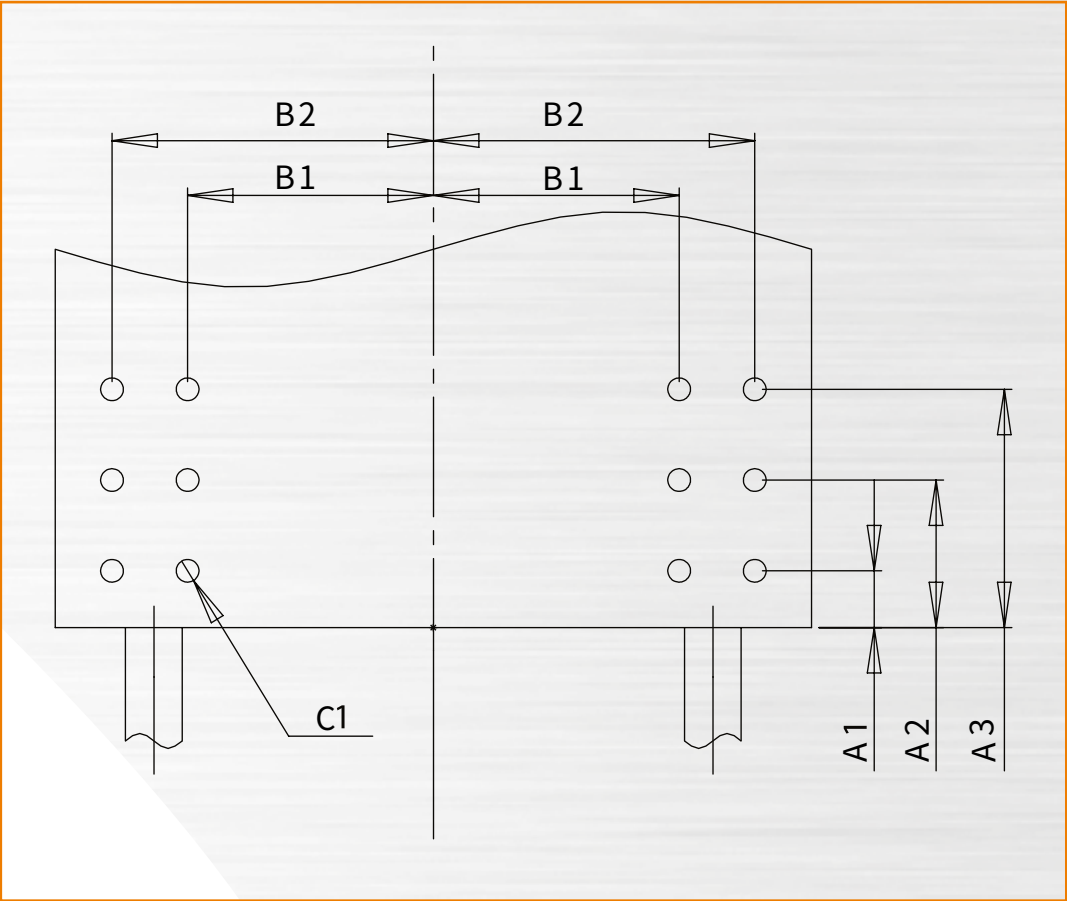



Chen Hsong Europe

Address: Hooghe Weg 4,47906
Kempen,Germany
Phone: +49(0)15204695827
Email: europe@chenhsong.com
Website: chenhsong.com

202206